

NEW P92 Echo MkII



The classic Tecnam Back to the Future.



SPECIFICATION AND DESCRIPTION



QUALITY AIRCRAFT SINCE 1948

TECNAM

Since 1994, the Tecnam P92 comes back with a new version: always high wing, two place, single engine airplane equipped with tricycle landing gear. The P92 Echo MkII comes today with up-to-date technology, composite fuselage, glass avionics and the same pleasant flying qualities: safe and easy to fly with beauty, inside and outside. The P92 Echo MkII has both metal wings and a metal stabilator.

Tecnam chose to construct the P92 Echo MkII with metal wings and stabilator structures for strength, reliability, and the ability to flex in flight, thereby ensuring a more comfortable ride. To produce the desired increase in cabin width and greater aerodynamic efficiency, Tecnam chose

carbon fibre.

The decision to use both materials was for the optimisation of aerodynamic qualities, flight characteristic, and reliability. This addition enables Tecnam to make construction decisions based on optimum design and structural integrity rather than purely the cost of production.

The doors which are lined with automotive type door seals, seats that give full support with excellent leg room, side map pockets as well as pockets in the back of the seats all combine to make the P92 MkII a very comfortable aircraft.

Some of the advantages: Superior performance and flight characteristics. Low stall speed with excellent response at all speeds. Stable and Responsive with uncompromising build quality (based on CS/VLA certified Aircraft). Excellent visibility, roomy, quiet and ergonomic.

The all movable type (stabilator) horizontal tail, traditional on Tecnam aircraft, allows excellent controllability and excellent "hands off" longitudinal stability.



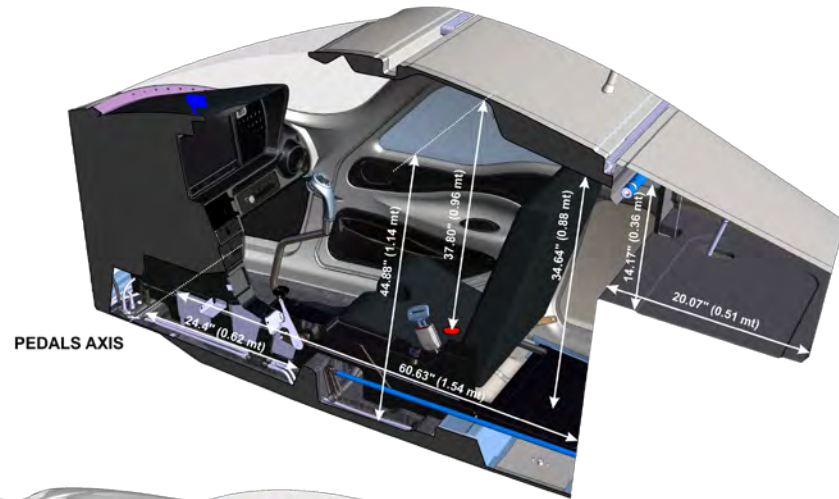

	472.5 kg ULM		912 600 kg ULM/LSA	
Max Cruise Speed KTAS	115 kts	213 km/h	115 kts	213 km/h
Stall Speed (Flaps Down Power Off) KCAS	35 kts	64 km/h	39 kts	72 km/h
Practical ceiling	14000 ft	4267 m	14000 ft	4267 m
Take off run	328 ft	100 m	460 ft	140 m
Take off distance	755 ft	230 m	885 ft	270 m
Landing Run	328 ft	100 m	393 ft	120 m
Landing Distance	755 ft	230 m	885 ft	270 m
Empty Weight	645 lb	293 kg	750 lb	340 kg



All estimated performance data are based on aeroplane weights at MTOW; standard atmospheric conditions; level, hard surface, dry runways, no wind. Empty weight could be $\pm 2\%$.

ROTAX 912 ULS

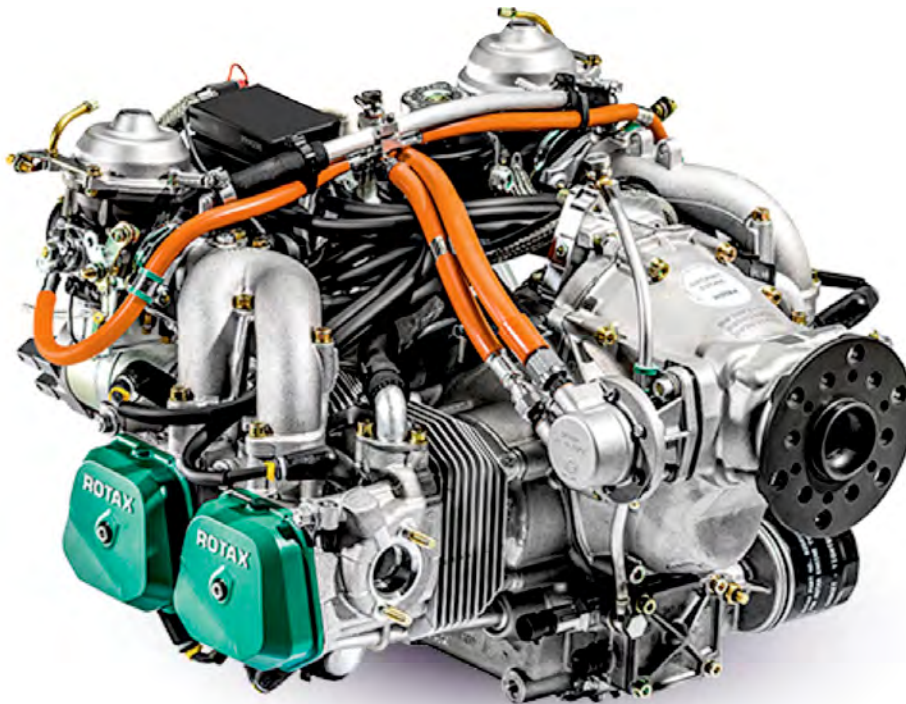

- Engine family 4-Stroke
- Number of cylinders 4
- Performance 7 3 kW / 99 HP
- Weight 56.6 kg
- Performance / RPM 73.5 kW / 5800 rpm
- Engine torque / RPM 128 Nm / 5800 rpm
- Gear Fix

ROTAX®

STANDARD EQUIPMENT

Flight Instruments And Indicators

- Magnetic Compass
- Airspeed Ind.
- Altimeter Dual Mode (In/Mb)
- Vertical Speed
- Bank Indicator
- Pitot System
- Static System
- Stabilator Trim Position Indicator

Engine Instruments

- Tachometer
- Hour Recorder
- Oil Press
- Oil Temp.
- Head Temp.
- Fuel Press.
- Voltmeter
- LH + RH Fuel Q.ty
- Stabilator Trim Position Indicator
- Flap Indicator

Flight Controls

- Hydraulic Toe Brakes
- Parking Brake
- Electrical Flaps
- Dual Flight Controls

- Steerable Nose Wheel
- Stabilator Trim (Electric Actuated From Stick)
- Engine Controls:
 - Central Quadrant With Single Throttle Lever
 - Choke
- Flight Trim Controls:
 - Stabilator With Indicator
- Fuel Control Selector Andair

Panel Switches:

- Starter Key ACS
- Split Starter

Electrical System

- 12 Volt 18A Amp. Battery
- 12 Volt Alternators-20 Amp.
- Circuit Breaker Panel
- 12 Volt Socket

Fuel System

- Two Integral Fuel Tanks With 95L 25 USgal Total Capacity
- Engine Driven Fuel Pump
- Fuel Tank Quick Drain , Two

Interior

- Pilot And Copilot Seats:
 - Adjustable Fore And Aft
- Seat Belts
- Wall To Wall Carpeting
- Map and Storage Pockets
- Luggage Compartments

Exterior

- Epoxy Corrosion Proofing, All Structure
- LH/RH Front Door Pilot/Copilot, Lock And Key
- All Lateral And Rear Windows Tinted Brown
- Main Wheels, 5,00 X 5
- Nose Wheel, 5,00 X 5
- Wheel Fairing

Exterior Lights

- Landing Light (No Led)

Cabin Comfort System

- Heating System
- Ventilator Adjustable 2 Place

Powerplant And Propeller

- Engines ROTAX 912 ULS 100Hp, 4 Cylinders
- Liquid/Air Cooled, Integrated Reduction Gear Dual Ignition System
- Throttle Control
- Tubular Steel Engine Mount
- Propeller Sensenich, 2 Blade Fix
- Propeller Spinner
- Air Filter
- Oil Filter
- Oil And Water Coolers

Product Support/Documents

- Manufacturers Full Two Year Limited Warranty
- Pilots Operation Handbook
- Maintenance Manual
- Parts Catalogue

AVIONIC OPTION 1

GARMIN G3X PACKAGE

Includes the following equipment:

- Two Display GDU 460 With EIS**
- GDU460
 - GDU460
 - ADAHRS GSU 25
 - GEA 24 Engine Instrument Module
 - GMU 22 Magnetometer

- GTP 59 Temperature Probe
- LRU KIT
- INSTALLATION KIT
- G3X SENSOR KIT
- GA 56 Antenna

C-1003 P92 ECHO MKII 100HP G3X

GSU Configuration

- Amps (Ammeter Shunt Or Hall Effect)
- Monitor Cht
- Aircraft Bus Voltages
- Oil Temperature
- Oat
- Oil Pressure
- Manifold Pressure
- Fuel Pressure
- Rpm
- Trim Indicator
- LH + RH Fuel Qty

Avionic Package

- GARMIN GMA 245 Audio Panel
- GARMIN GTR 225A COM
- GTX 35R Transponder mode S remote mounted
- ELT KANNAD 406 Mhz
- STICK PUSH-TO-TALK SWITCH-PILOT/COPILOT
- MIC & PHONE JACKS-PILOT/COPILOT

Antennas:

- Transponder
- VHF
- GPS
- ELT



C-1004 P92 ECHO MKII 100HP G3X EU 600 Kg Package

Includes:

- Emergency Parachute System BRS



Some images may contain optional items not included in the standard. Option also pictured.



OPTIONAL EQUIPMENT

C-1005

P92 ECHO MkII 100HP US LSA

- Extended Warranty for Rotax Engine (1 year extension)
- Fire Wall Inox
- Airspeed Ind., Kts
- Panel Switches:
- Tie Down Rings
- Fire Sleeve On Fuel and Oil Tubes
- Thermostatic Valve Oil
- Baggage Compartment Net
- External Power Supply
- Taxi Light LED
- Wing Light Green/Red, White and Strobe AVEO
- Auxiliary Fuel Pumps, Electric
- Windshield Defroster

Non-Additive. Replaces all Standard Avionics. Some images may contain optional items not included in the standard. Option also pictured.



STANDARD

- S11_ Color Stripes**
- FS/896.11 BLUE
 - FS/897 BLACK

- S12_ Color Stripes**
- XF/999.2 GOLD
 - XF/996.5 DARK BLUE

- S13_ Color Stripes**
- FS/893.13 RED
 - FS/897 BLACK

- S14_ Color Stripes**
- XF/996.5 DARK BLUE
 - FS/893.13 RED



SPECIAL PAINT

- Sp1_ Paint Stripes**
- SMOKE GRAY
 - FS/897 BLACK
 - FS/893.13 RED

- Sp3_ Paint Stripes**
- RED
 - FS/897 BLACK
 - 546 FS/899.1 SILVER

- Sp2_ Paint Stripes**
- NAVY BLUE
 - XF/999.2 GOLD
 - FS/899.1 SILVER

- Sp4_ Paint Stripes**
- GREEN
 - 502 BLACK

Cockpit

Roof: *Dark Grey*

Glareshield: *Black*

Doors: *Medium and Dark Grey*

Dashboard: *Black*

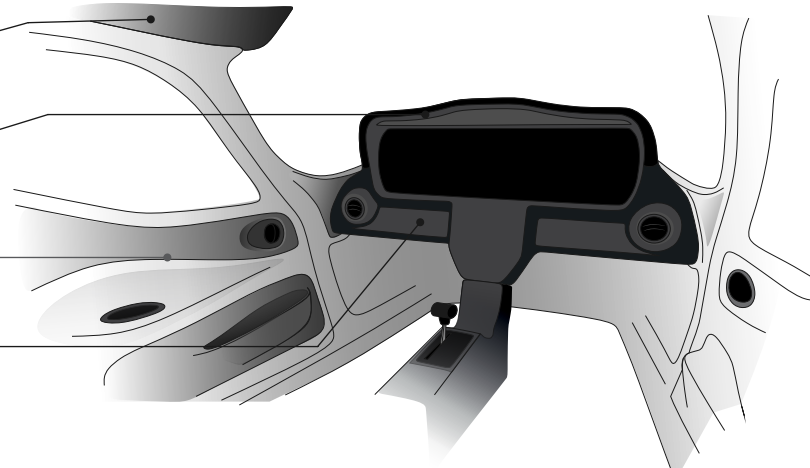

Standard seats



De Luxe seats





1948 - 2018
70
YEARS

20112015

Pascale Museum at Tecnam Headquarters Capua

Costruzioni Aeronautiche Tecnam SpA
Via Maiorise 81043 Capua CE - Italy
Tel. +39 0823 622297 Fax. +39 0823 622899
www.tecnam.com info@tecnam.com

<https://www.tecnam.com/aircraft/p92-echo-mkii/>

 **QUALITY AIRCRAFT SINCE 1948**
TECNAM